

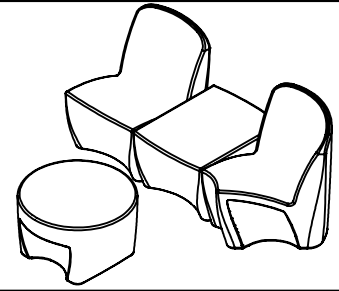

Pax Bolt Down and Ganging Assembly Instructions



www.norix.com • TEL 800 234-4900

Model Number
PX11-XXX, PX13-XXX,
PX40-XXX, PX42-XXX

Assembly Notes: Norix is not responsible for any damage due to improper installation. If your shipment does not match the parts list, please contact Norix Customer Service at 800-234-4900. Norix reserves the right to modify design specifications at any time without an obligation to owners of previously sold products.

Parts List (Bolt Down)			
ITEM	QTY.	PART NUMBER	DESCRIPTION
A	1	PXYX-XXX	Pax Product
B	2	011-081	Pax, Bolt Down Plate
C	4	021-080	Screw, Machine 1/4-20 X .75, BH, T-in-P, T-27

Tools Needed
Low RPM Variable Speed Drill (071-001) Torx in Pin® T-27

Parts List (Ganging)			
ITEM	QTY.	PART NUMBER	DESCRIPTION
A	1	PX11-XXX, PX13-XXX, PX40-XXX	Pax Product (Except PX42-XXX)
E	1	011-080	Pax, Ganging Plate
C	4	021-080	Screw, Machine 1/4-20 X .75, BH, T-in-P, T-27
D	4	026-006	Washer, Flat, 11-32 ID x 3-4 OD x .050 18-8 SST

Bolt Down:

- HAND THREAD SCREW (C) THROUGH BOLT DOWN PLATE (B) AND INTO PAX PRODUCT (A) AS SHOWN IN DETAIL A.
- FINISH TIGHTING (Detail C), PLACE ON GROUND AND MARK ANCHOR LOCATIONS.

NOTE: IF MORE THAN ONE PAX PRODUCT IS BEING BOLTED DOWN, A GANGING PLATE SHOULD BE USED ON THE MIDDLE PRODUCTS AS SHOWN BELOW. THE END PRODUCTS ARE BOLTED DOWN AFTER EVERYTHING IS GANGED TOGETHER.

Ganging (Not Available for Ottoman PX42):

- HAND THREAD SCREW THROUGH (C), THROUGH WASHER (D) THROUGH GANGING PLATE (E) AND INTO PAX PRODUCT (A) AS SHOWN IN DETAIL B.
- FINISH TIGHTING.

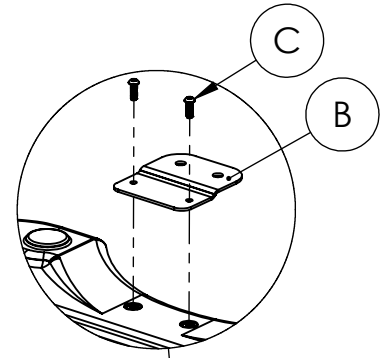

DETAIL A
SCALE 1 : 8

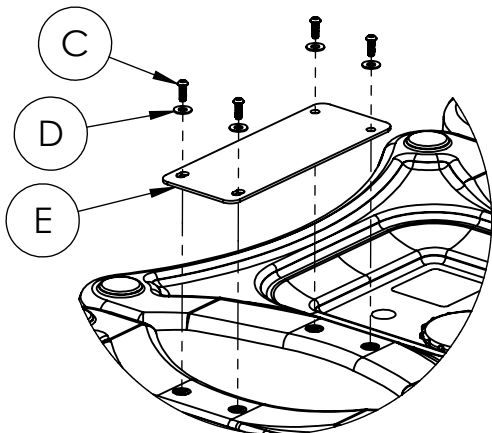

DETAIL B
SCALE 1 : 8

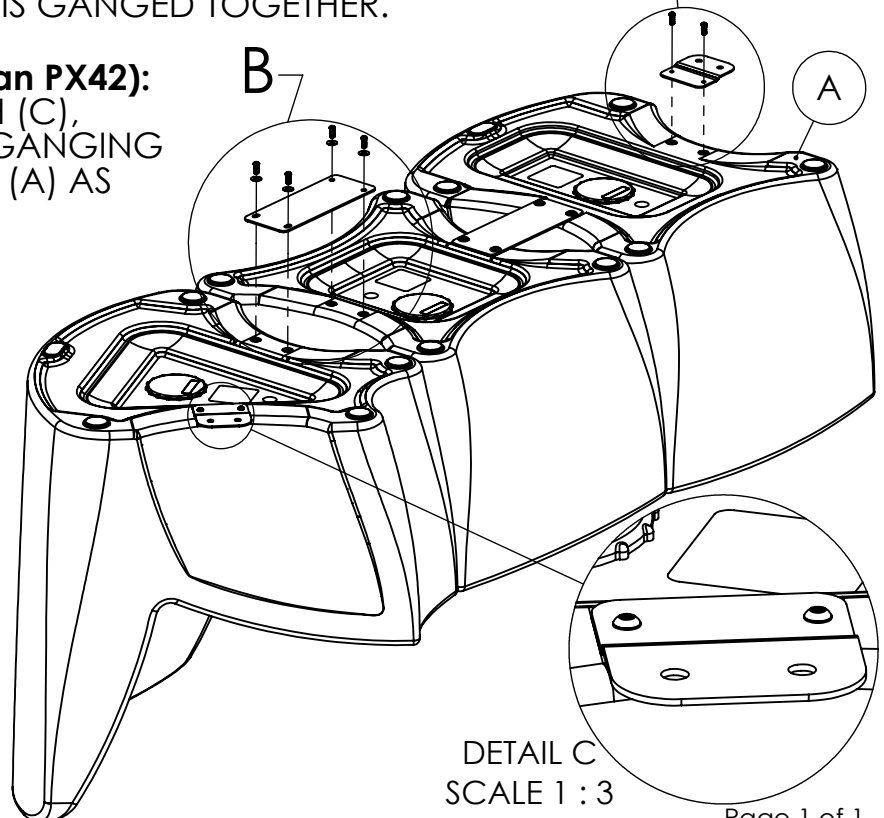

DETAIL C
SCALE 1 : 3