

Assembly Notes: Norix is not responsible for any damage due to improper installation. If your shipment does not match the parts list, please contact Norix Customer Service at 800-234-4900. Norix reserves the right to modify design specifications at any time without an obligation to owners of previously sold products.

PARTS LIST

ITEM	QTY	PART NUMBER	DESCRIPTION
A	1	Table Top	Table Top, Multi-Base Pattern
B	1	030-007/030-006	Plate, Slammer Kit
C	1	030-026/030-036	Base, X-Slammer, Bottom, Top Groove
D	1	030-027/030-037	Base, X-Slammer, Top, Bottom Groove
E	12	021-003	Screw, Machine 5/16"-18 x 1-3/4" L, Black Oxide

STEP 1: Stand the X-Slammer Base (C) with the Top Groove, so that the flat head screws are up. Form "X" base by sliding the other X-Slammer Base (D) with the Bottom Groove in to the other Bases Groove.

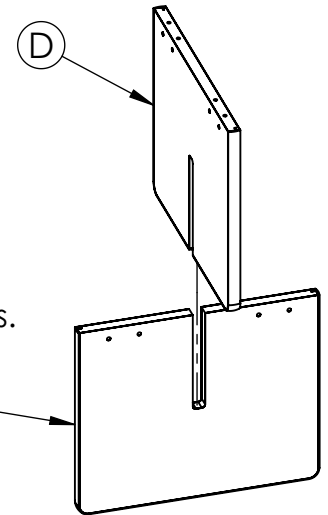

STEP 2: Remove the 8 flat head screws from the table bases. Place the base plate down over the table base so that there are 8 tapered holes up, and complete the table base by reinserting the 8 flat head screws through the base plate and into the X-Slammer Bases.

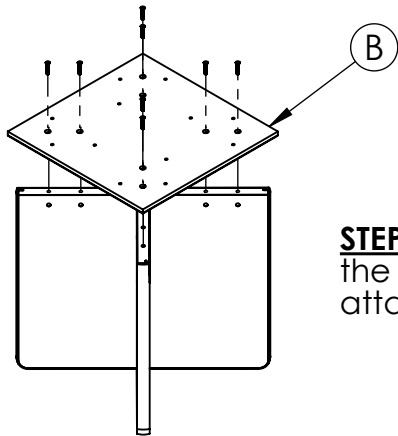

STEP 3: Place the Table Top (A) on a soft protective flat surface with the bottom side up. Invert the table base and place on the table top attach the table base to the table top using 12 Machine Screws (E).

