

Hondo Nuevo Locking Ganging Kit for Plinth Bases, Molded Leg and Wood Leg Assembly Instructions

Model Number:
C011-019

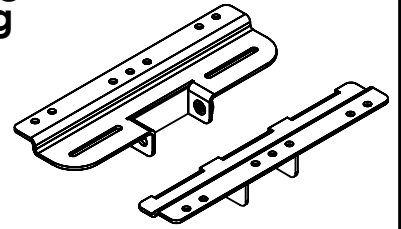

www.norix.com • TEL 800 234-4900

Assembly Notes: Norix is not responsible for any damage due to improper installation. If your shipment does not match the parts list, please contact Norix Customer Service at 800-234-4900. Norix reserves the right to modify design specifications at any time without an obligation to owners of previously sold products.

PARTS LIST

ITEM NO.	QTY.	PART NUMBER	DESCRIPTION
A	1	011-031	Hondo Nuevo, Ganging Brkt, Molded Base, Locking, Female
B	1	011-032	Hondo Nuevo, Ganging Brkt, Molded Base, Locking, Male
C	1	060-195	Hondo Nuevo Ganging Bracket Locating Tool
D	6	021-144	Screw, Sheet Metal, #10-16 X 1.5", BH, Pin-in-Torx® T-25, Blk. Ox.
E	1	025-011	Lock Washer, 5/16" Split, Zinc
F	1	026-006	Washer, Flat, 11/32" ID X 3/4" OD, SS
G	1	021-017	Screw, Machine, 5/16-18 X 3", BH, Pin in Torx® T-40, Steel, Zinc
	1	071-007	Pin in Torx® Driver T-25
	1	071-002	Pin in Torx® Driver T-40

Tools Needed

Variable Speed Drill
Pin in Torx® Driver T-25
Pin in Torx® Driver T-40
Driver Extension, 12" Long

Read and understand instructions completely before assembly. Determine the front of each unit to be ganged. Some units are symmetrical from front to back.

1. Turning the furniture units upside down will simplify assembly. Typically, the bracket with the slots (A) should be attached to the unit that will be on the left.

Place bracket (A) on unit as shown. The front of the bracket should be 9.5" from the front, lower edge of the unit. Use the locating tool (C) to help determine this measurement. Mark the location on the unit, if needed.

Remove any existing screws that would interfere with the location of the bracket.

2. The inside edge of the slot should be aligned with the side of the unit as shown.

Attach the bracket to the unit using (3) #10 Screws (D). **Do not overtighten screws.** Extra holes are provided to be used as necessary.

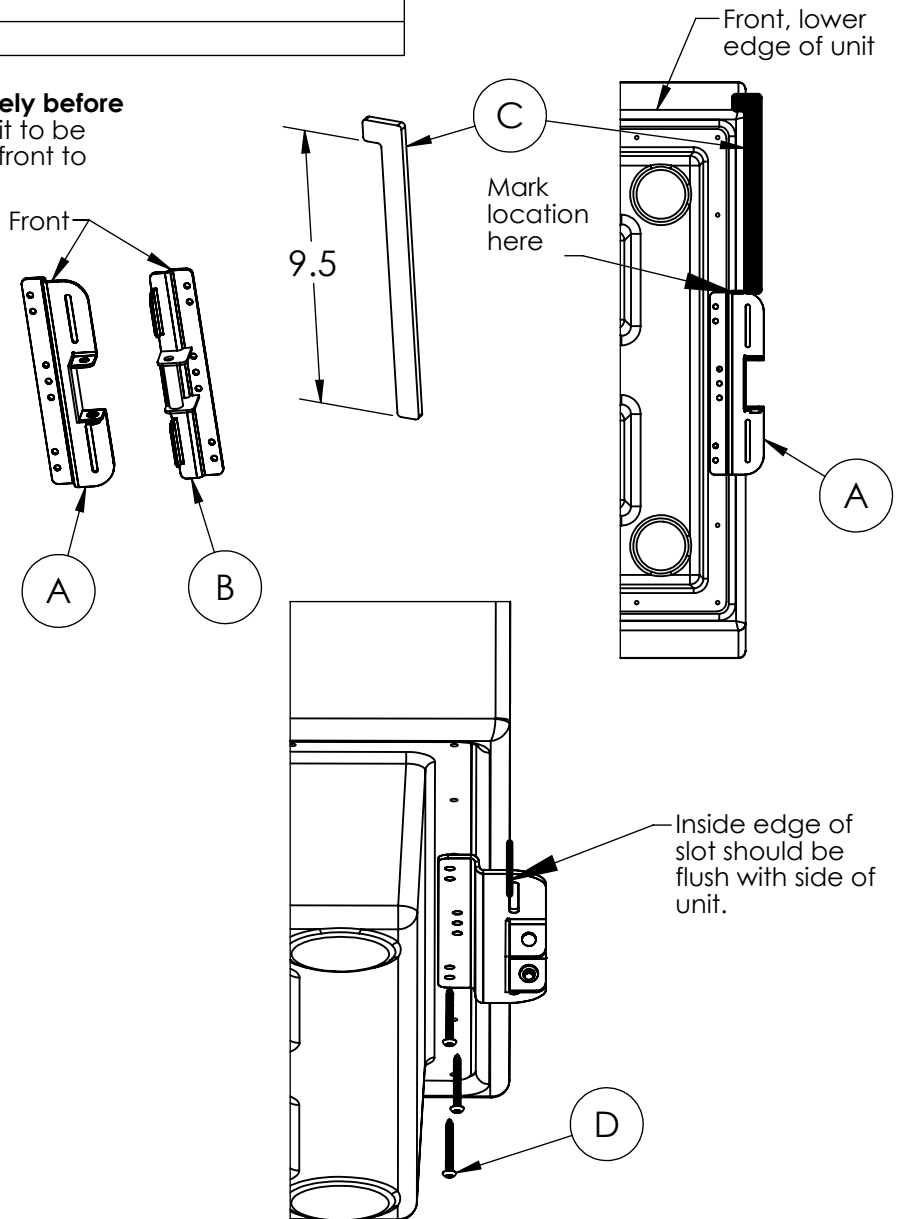

Typically, the bracket with the tabs (B) should be attached to the unit that will be on the right.

3. Place bracket (B) on unit as shown. The front of the bracket should be 9.5" from the front of the unit. Use the locating tool (C) to help determine this measurement. Mark the location on the unit, if needed.

Remove any existing screws that would interfere with the location of the bracket.

4. The outer face of the tabs should be flush with the side of the unit as shown.

Attach the bracket to the unit using (3) #10 screws (D). **Do not overtighten screws.** Extra holes are provided to be used as necessary.

5. (Optional): Secure the units together with hardware. Insert the tabs on bracket (B) into the slots on bracket (A).

The fronts of the units should be aligned.

Assemble the 5/16 Screw (G), Lock Washer (E), and Flat Washer (F) as shown. Use a driver extension to install the hardware if the units are upright on the floor. Tighten hardware securely.

6. Assembly complete.

