

Titan Bunkable Panel Bed Assembly Instructions

Model Number
TNT1X1X

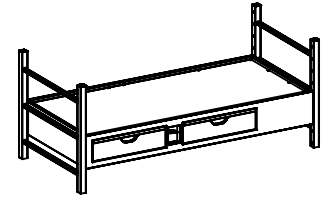

www.norix.com • TEL 800 234-4900

Assembly Notes: Norix is not responsible for any damage due to improper installation. If your shipment does not match the parts list, please contact Norix Customer Service at 800-234-4900. Norix reserves the right to modify design specifications at any time without an obligation to owners of previously sold products.

Parts List				Tools Needed
ITEM	QTY.	PART NUMBER	DESCRIPTION	
A	1	TNT1X4X	Panel Bed	Non-secure hdw.: 3/16 Ball-End Hex Driver
B	2	036-T001-XX	Bunkable Steel End Frame	Secure hdw.: T-40 Pin-in-Torx Driver
C	8	021-101/021-102	Standard: Screw 5/16-18 X 1.5 L, Hex Skt, Btn Head (Zinc/Blk)	T-45 Pin-in-Torx Driver (unit with drawers)
C	8	021-116/021-007	Security: Screw 5/16-18 X 1.5 L, Btn Hd, T40 Pin-in-Torx (Zinc/Blk)	Optional: Variable speed drill
D	8	025-011/025-030	Washer, Lock, 5/16	See below for additional recommended tools
E	8	026-006/025-031	Washer, Flat, 11/32 ID X 3/4 OD X 0.050	

Recommended tools:

For non-security hardware: A 3/16" **ball-end** hex driver.

A T-handle ball-end hex driver makes this installation easy (available from McMaster-Carr, part no. 37095A52).

--OR--

A 1/4" drive ratchet wrench and socket extension that is 6" or longer. A longer extension (10" or 12") makes the job easier.

A flexible bit driver (McMaster-Carr part no. 85255A13) can be used with a drill, but is not necessary.

1. If bed has drawers, remove the drawer closest to the end of the bed. A T45 Pin-in-Torx Driver must be used to extract drawer stop hardware.

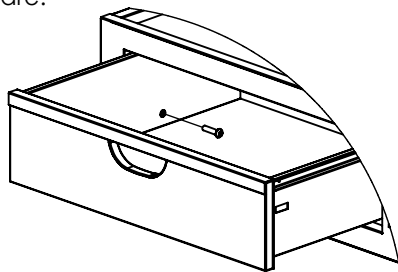

2. Tip the bed on its side. Place a corner protector from the packaging underneath at each end to elevate the ends of the bed. The protectors should be folded so that they are double thickness. If the protectors have been discarded, use any spacer that is about 3/8" thick, ensuring that the bed does not get scratched.

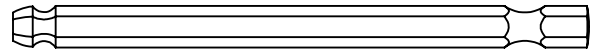
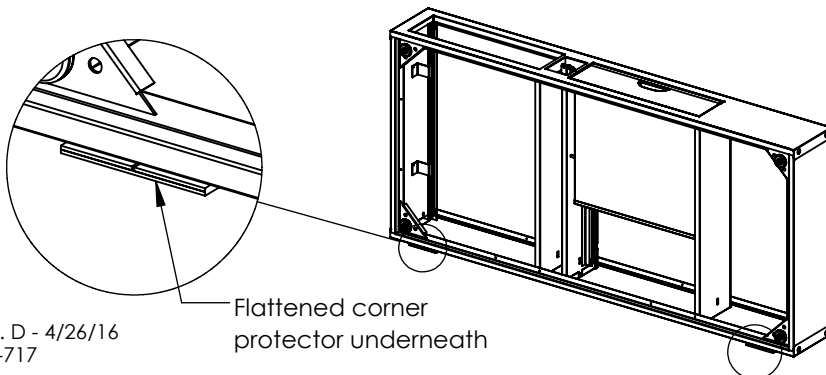

3/16" Ball-End Hex Driver - shown full size

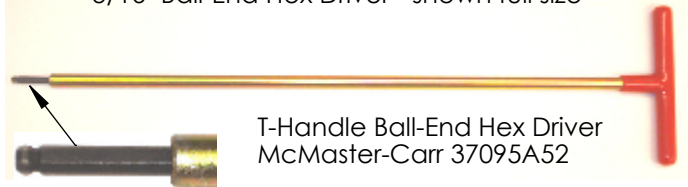

T-Handle Ball-End Hex Driver
McMaster-Carr 37095A52



Socket Extension



Flexible Bit Driver
McMaster-Carr 85255A13



Ratchet & Extension

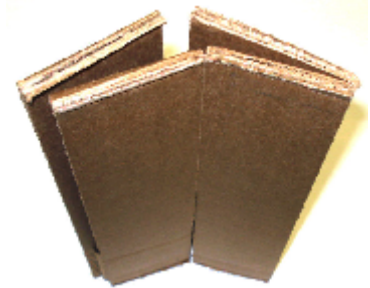

Corner Protector
from packaging

3. Using a ball-end driver on an extension, knock out the (4) hole plugs at each end of the bed.

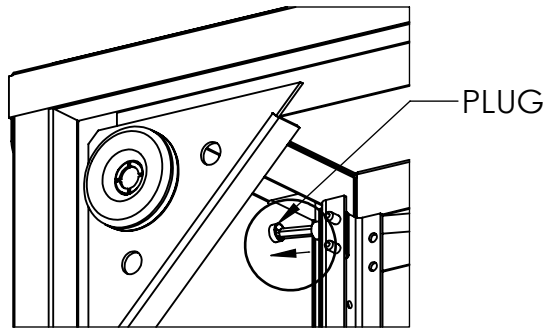

4. Place (4) of the attachment screws (C), lockwashers (D), and flat washers (E) into the holes in one end of the bed.

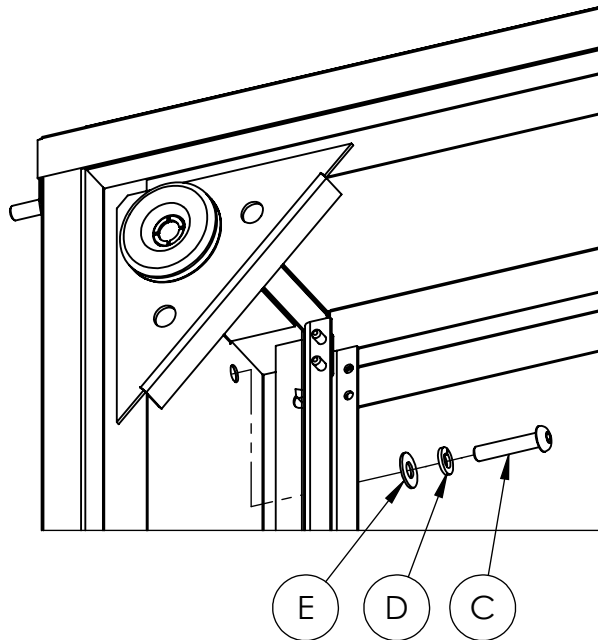

5. Orient the End Frame correctly (see drawing at right) and align the selected (4) threaded holes in the End Frame with the screws in the bed.

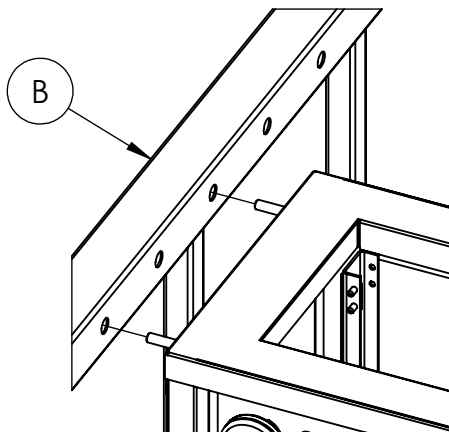

6. Lift the End Frame to align one of the threaded holes with its mating screw, and use your fingers to start the screw into the end frame. **Do not cross-thread the screws.** The screws should turn easily with fingers if the screws are aligned correctly. If turning by hand is not possible, a ball-end hex driver with an extension can be used to start the screw (T40 Pin-in-Torx Driver for security hardware). Turn the screw into the End Frame only a couple of threads. Repeat this process with the other screw. (see photo below)

Repeat the above step for the (2) screws on the other corner at this end of the bed.

Once all (4) screws are started, use a ball-end driver (or T40 Pin-in-Torx driver for security hardware) to tighten all of the screws.

