

Assembly Notes: Norix is not responsible for any damage due to improper installation. If your shipment does not match the parts list, please contact Norix Customer Service at 800-234-4900. Norix reserves the right to modify design specifications at any time without an obligation to owners of previously sold products.

PARTS LIST			
ITEM	QTY	PART NUMBER	DESCRIPTION
A	1	034-501-XX	Leg, MaxMaster, 14ga, 3" Dia, Bolt Down
B	1	050-407	Desk, Econo-Max 16x24 W/Studs, 11Ga 304SS
C	1	040-060 / 040-00XXX	Seat, Ironman, 12", SST, 14 Ga, 5/16-18 x 5/8 Stud / Slammer Stone Seat
D	4	025-007	NUT, HEX, 5/16-18, LOCTITE
E	4	025-011	Washer, Lock, Split, 5/16", Blk Ox.
F	1	024-001	Anchor, Concrete, Wedge, 3/8"-16 X 3.5", Zinc
G	1	026-008	Nut/Washer Assy. 3/8"-16, Zinc, Thd. Lk.
H	4	026-010	Nut, 3/8-16, Steel, Zinc, Thd Lk
I	4	025-009	Washer, Flat, 3/8"
J	4	025-006	Washer, Lock, Split, 3/8, Zinc
k	4	021-001	Screw 5/16-18 x 5/8, FH, Pin in Torx (Super Slammerstone Seat)

Tools Needed
Low RPM Variable Speed Drill
1/4" Hex Driver
3/8" Concrete Drill Bit
24" Socket Extension
5/8" Magnetic Deep Socket
Rubber Mallet

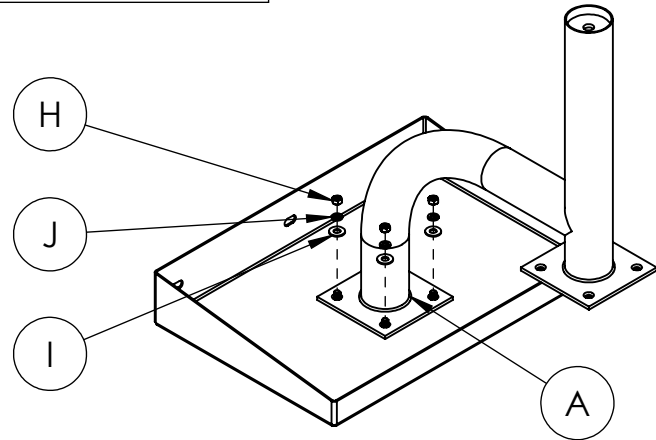
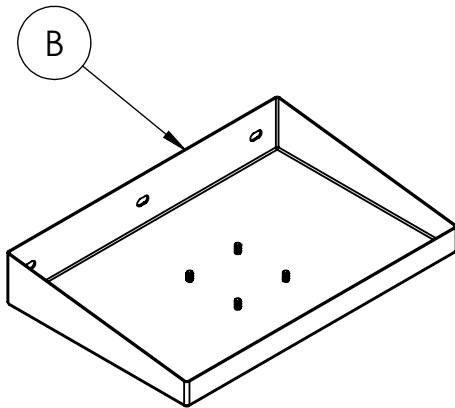

**STEP 1:** Locate the Top (B) on the Packaging cardboard or other soft work space to avoid scratching the product.

**STEP 2:** Attached the Leg (A) to the Table Top (B) and secure the Leg to the Top using (4) Flat Washer (I), (4) Washer Lock (J), and (4) NutS (H).

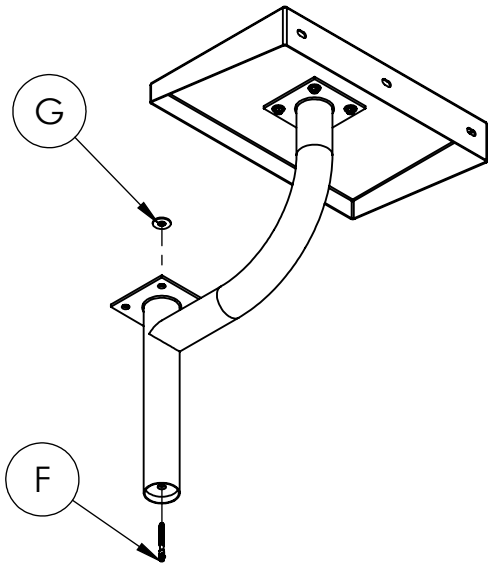

**STEP 4:**

Drill holes through the floor. Drive Anchors (F) to the floor and secure the Top with Leg using 3/8" Flange Nuts (G) as shown.

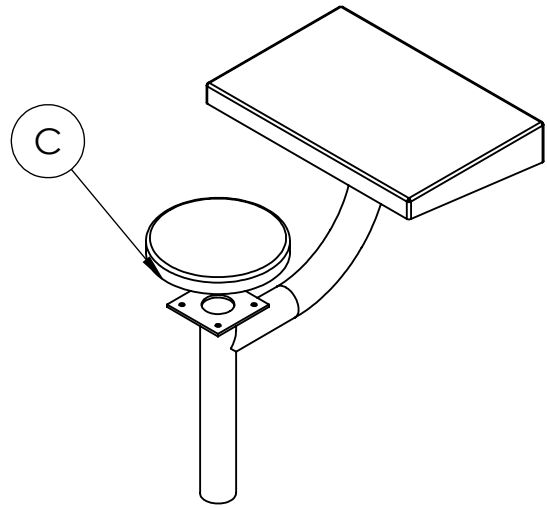

**STEP 5:**

Position a Seat (C) over the Leg as shown.

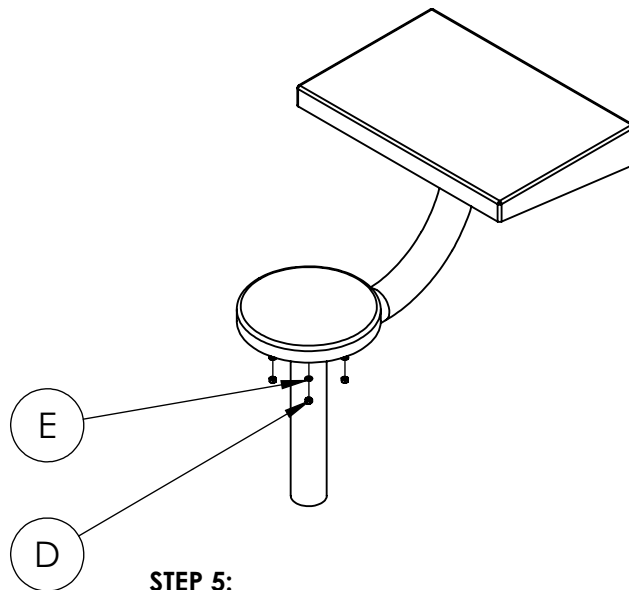

**STEP 5:**

Secure Seat with (4) 5/16 Lock Washers (E) and (4) 5/16-18 Nuts (D). If you are using Slammer Stone Seats, secure the seat with (4) 5/16-18 Flat Head Screws (k).