

Assembly Notes: Norix is not responsible for any damage due to improper installation. If your shipment does not match the parts list, please contact Norix Customer Service at 800-234-4900. Norix reserves the right to modify design specifications at any time without an obligation to owners of previously sold products.

PARTS LIST. Molded Edge & SS Quiet Core Tops (Hardware Per Each Leg)				Tools Needed
ITEM	QTY	PART NUMBER	DESCRIPTION	Low RPM Variable Speed Drill
A	1	05X-XXXX	Top, Max Master, Molded-Edge	1/4" Hex Driver
B	1	034-501/034-701	MAX MASTER LEG 3" Bolt Down/With Glides	Rubber Mallet
C	4	021-002	Screw, Machine 5/16"-18 X 1-1/4" L, FH, Pin in Torx® T40, Black Oxide, Thd. Lk.	

STEP 1

Prior to assembly - Open all packaging and confirm Parts List.
Keep all panels on a protective surface during assembly.
Be sure to hand start all screws/nuts to avoid cross-threading.

STEP 2a

Attach the Leg (B) to the Table Top (A)
and secure the Leg to the Top using
(4) 5/16"-18 X 1-1/4"L Screws (C).
Repeat for each leg.

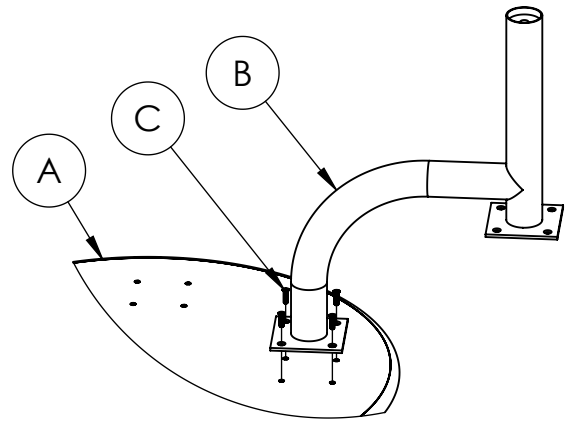

PARTS LIST. SST Top With Studs (Hardware Per Each Leg)

ITEM	QTY	PART NUMBER	DESCRIPTION
A	1	050-XXX	Top, Max MASTER, Top, 10Ga SST W-Studs
B	1	034-501/034-701	MAX MASTER LEG 3" Bolt Down/With Glides
C	4	025-006	Washer, Lock, Split, 3/8, Zinc
D	4	026-010	Nut 3/8-16 With Locktite

STEP 2b

Attach the Leg (B) to the Table Top (A)
and secure the Leg to the Top using
(4) 3/8 Washers (C) and (4) 3/8-16 Nuts(D).
Repeat for each leg.

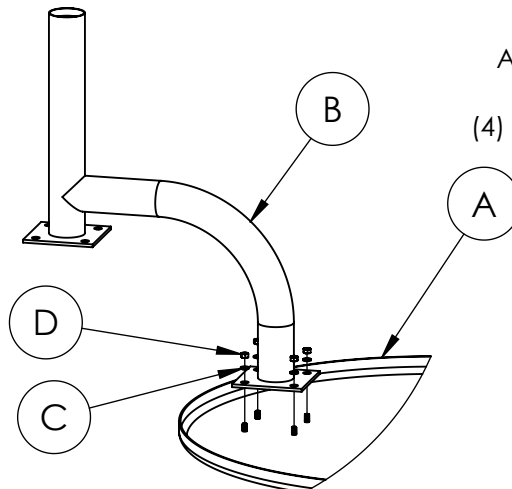

PARTS LIST. SST Top With Channels (Hardware Per Each Leg)

ITEM	QTY	PART NUMBER	DESCRIPTION
A	1	050-XXX	SST Top With Channels
B	1	034-501/034-701	MAX MASTER LEG 3" Bolt Down/With Glides
C	4	021-001	Screw, Machine 5/16"-18 X 5/8" L, FH, Pin in Torx® T40, Black Oxide, Thd. Lk.

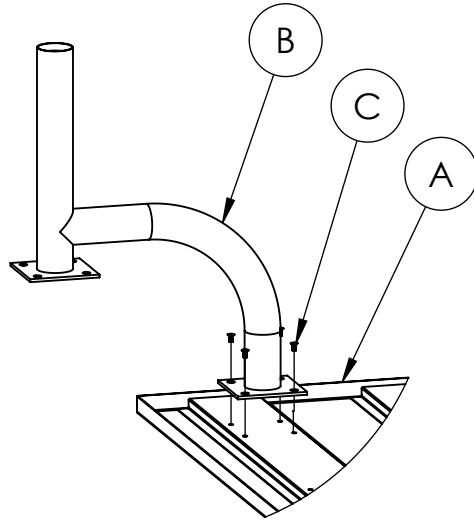

STEP 2c

Attach the Leg (B) to the Table Top (A) and secure the Leg to the Top using (4) 5/16"-18 X 5/8"L Screws(C). Repeat for each leg.

BOLT DOWN VERSION

PARTS LIST			
ITEM	QTY	PART NUMBER	DESCRIPTION
F	1	024-001	Anchor, Concrete, Wedge, 3/8"-16 X 3.5", Zinc
G	1	026-008	Nut/Washer Assy. 3/8"-16, Zinc, Thd. Lk.

Tools Needed
3/8" Concrete Drill Bit
24" Socket Extension
5/8" Magnetic Deep Socket

Before Seat Installation.

Turn the Table right side up. Mark the anchor spots in the desired location and drill holes into the floor. Drive Anchors (F) into the floor and secure the table with Legs using 3/8" Flange Nuts (G) as shown. Repeat for each leg.

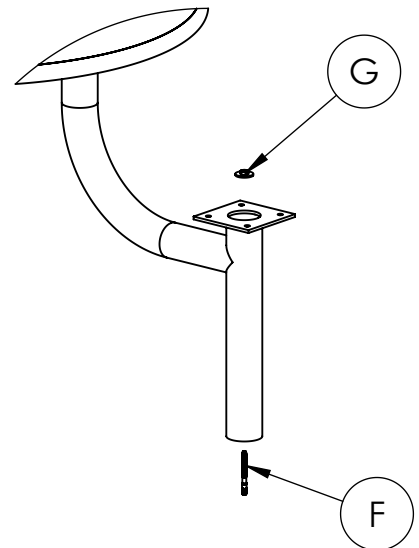

PARTS LIST. Slammer Stone Seat (Hardware Per Each Leg)

ITEM	QTY	PART NUMBER	DESCRIPTION
A	1	040-0XXX	Seat, 13" Super Slammer Stone
B	4	021-001	Screw, Machine 5/16"-18 X 5/8" L, FH, Pin in Torx® T40, Black Oxide, Thd. Lk.

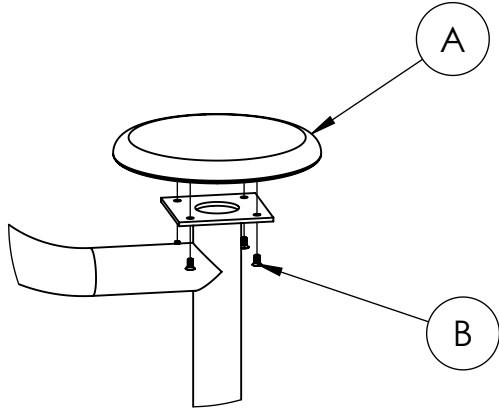

STEP 3a

(Note: Do this step last if bolting to floor)
Secure Seat (A) to the Leg using
(4) 5/16-18 X 5/8"L Flat Head Screws (B).
Repeat for each seat.

PARTS LIST. Stainless Steel Seat With Studs (Hardware Per Each Leg)

ITEM	QTY	PART NUMBER	DESCRIPTION
C	1	040-060	Seat, Ironman, 12", SST, 14 Ga, 5/16-18 x 5/8 Stud
D	4	025-030	Washer, Lock, Split, 5/16", Blk Ox.
E	4	025-007	NUT, HEX, 5/16-18, LOCTITE

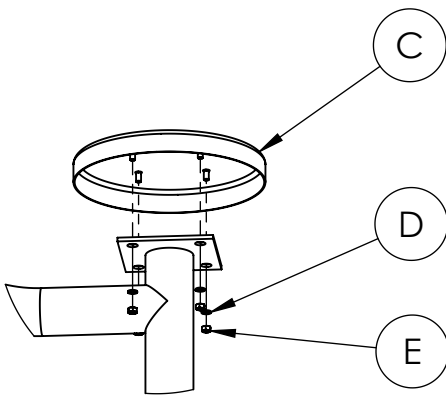

STEP 3b

(Note: Do this step last if bolting to floor)
Secure Stainless Steel Seats (C), with
(4) 5/16 Washers (D) and (4) 5/16-18 Nuts (E).
Repeat for each seat.