

Economax Tables W/Quietcore Top Assembly Instructions

Model Number

M42X-XXXX

M62X-XXXX

Assembly Notes: Norix is not responsible for any damage due to improper installation. If your shipment does not match the parts list, please contact Norix Customer Service at 800-234-4900. Norix reserves the right to modify design specifications at any time without an obligation to owners of previously sold products.

1) Two people required for proper assembly.

Parts List (Hardware Per Each Leg)

ITEM	QTY	PART NUMBER	DESCRIPTION
A	1	05X-XXXX	Table Top
B	1	034-505 / 034-705	Economax Leg Bolt Down / Economax Leg With Glides
C	1	040-0XXX / 040-060	Super Slammerstone Seat / Stainless Steel Seat
D	4	021-050	Screw 5/16-18 x 1 BH, Pin in Torx Blk Loctite
E	4	021-001	Screw 5/16-18 x 5/8, FH, Pin in Torx (Super Slammerstone Seat)
F	1	024-001	Concrete Anchor (Bolt Down)
G	1	026-008	3/8-16 Nut/Flanged (Bolt Down)
H	4	025-011	Washer Lock, 5/16 (Stainless Steel Seat)
I	4	025-007	Nut 5/16-18 Steel Zinc (Stainless Steel Seat)
J	4	025-006	Washer Lock, 3/8 Zinc

Tools Needed	Tools Needed
Low RPM Variable Speed Drill	3/8" Concrete Drill Bit
1/4" Hex Driver	24" Socket Extension
Rubber Mallet	5/8" Magnetic Deep Socket

STEP 1

Prior to assembly - Open all packaging and confirm Parts List. Keep all panels on a protective surface during assembly. Be sure to hand start all screws/nuts to avoid cross-threading.

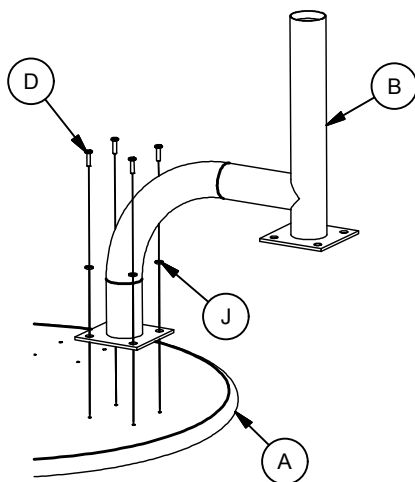

STEP 2:

Attached the Leg (B) to the Table Top (A) and secure the Leg to the Top using (4) 3/8 Lock Washers (J) and (4) 5/16-18 Screws (D). Repeat for each leg.

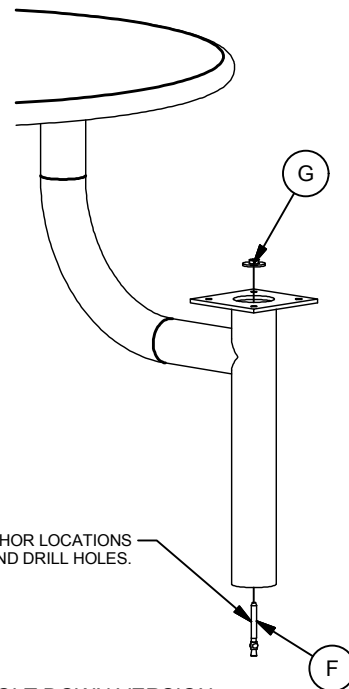

MARK ANCHOR LOCATIONS AND DRILL HOLES.

BOLT DOWN VERSION

Turn the Table right side up. Mark the anchor spots to the desired location and drill holes through the floor. Drive Anchors (F) to the floor and secure the table with Legs using 3/8" Flange Nuts (G) as shown. Repeat for each leg.

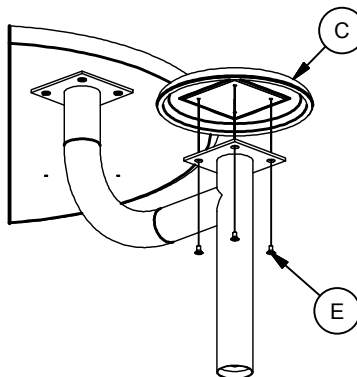

STEP 3: (Note: Do this step last if bolting to floor)

Secure Seat (C) to the Leg using (4) 5/16-18 Flat Head Screws (E). If you are using Stainless Steel Seats, secure the seat with (4) 5/16 Washers (H) and (4) 5/16-18 Nuts (I). Repeat for each seat.