

Assembly Notes: Norix is not responsible for any damage due to improper installation. If your shipment does not match the parts list, please contact Norix Customer Service at 800-234-4900. Norix reserves the right to modify design specifications at any time without an obligation to owners of previously sold products.

Parts List

ITEM	QTY	PART NUMBER	DESCRIPTION
A	1	ATN601-XXX	Desk, Attenda, Bolt Down
B	4	011-023	Bracket, Bolt Down, Attenda Desk
C	4	021-051	Screw, Machine, 5/16-18 x 5/8" BH Pin in Torx T40, Zinc, Thd Lk

Tools Needed

Low RPM Variable Speed Drill
3/8" Concrete Drill Bit
Driver for Anchor
Pin in Torx® T40 Driver

1. Temporarily place the desk in the desired location.
2. Slide the (4) Brackets (B) into the recesses, ensuring that the slotted holes face inward.

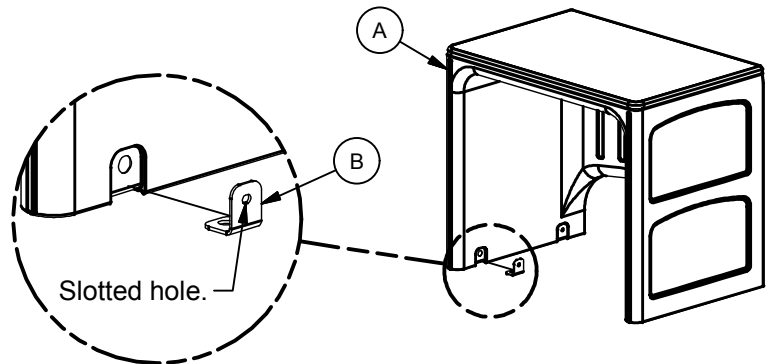

3. Place masking tape on the floor along the edge of each bracket, as shown, and mark the edge and ends of the brackets.

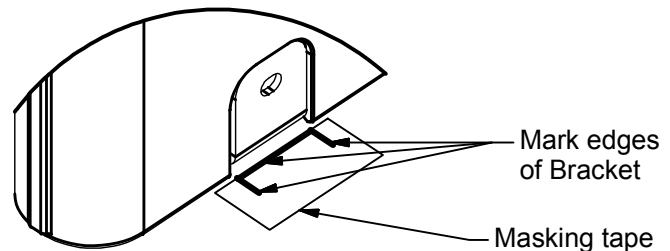

4. Set the desk aside. Using the markings on the tape, place the brackets in their mounting locations. Trace the round holes onto the floor and proceed with installing anchors into the floor.

5. Place the brackets over the anchors and secure with mounting hardware. (Mounting Hardware not provided)

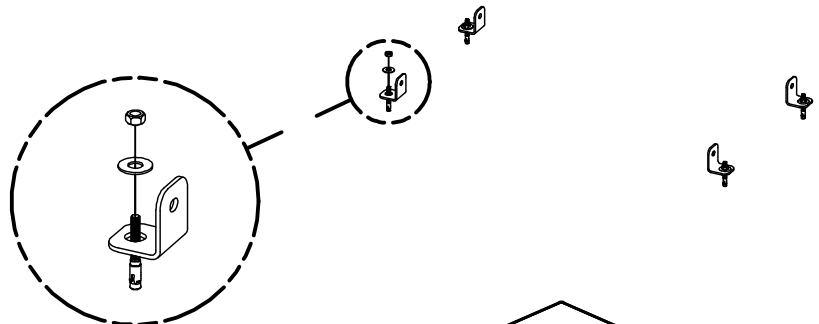

6. Place the desk into final position and install (4) Machine Screws (C) through the Brackets (B) and into the threaded holes in the Desk.

